

JANUS CONTROL VALVE RELIEF VALVE

A patented range of valves which can control the pressure of corrosive fluids in hydraulic systems. Designed specifically for fluids with low viscosity, the valve offers accurate control with high resistance to flow erosion experienced in pressure control applications. The valve fully conforms to the Pressure Equipment Directive and can include internal burst disc assemblies for safety applications.

SPECIFICATION	
Max Inlet Pressure	180 Bar
Operating Pressure Range	1 10 to 30 Bar 2 70 to 160 Bar 3 >160 bar 4 25 to 100 Bar
Flow Range	- DN3 0-10 L/min - DN6 0-30 L/min - DN12 0-120 L/min - DN16 0-450 L/min
Construction Materials	316 Stainless Steel Polymer or Ceramic
Media	Water

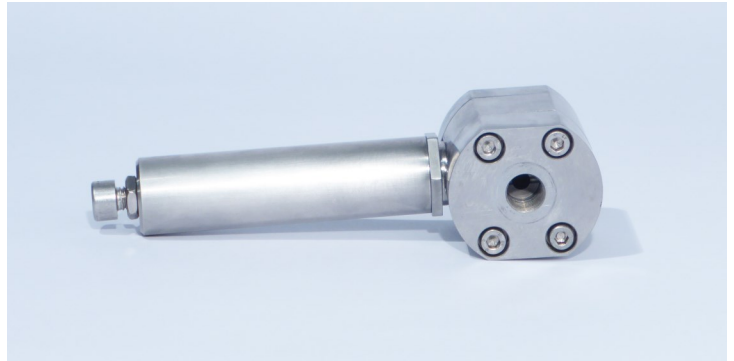

Seals

Standard valves are supplied with Nitrile seals however, alternatives are available on request.

Noise

The valve offers very low noise output even when relieving at high system pressures. The usual high pitch "squeal" associated with water relief valves is not generated with this range of valves.

Relief Setting





The operating pressure range must be specified on all orders. Not only the spring force varies with pressure but also the actuation piston is sized to give both accuracy and precision in low, medium and high pressure valves.

Drip rate

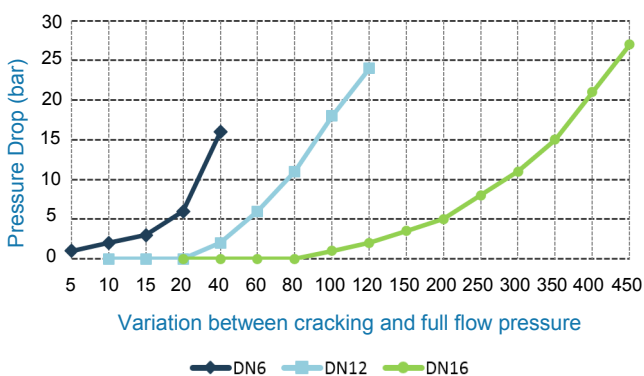
The valves do not offer 100% seal below set pressure. A drip rate when operating at 75% of its set pressure will result.

Flow Characteristics



ORDERING CODE	DN6	DN6 MANIFOLD	DN12	DN16
 10-30 bar	107BXS	1M07BXS	107DXS	107EXS
 25-100 bar	407BXS	4M07BXS	407DXS	407EXS
 70-160 bar	207BXS	2M07BXS	207DXS	207EXS
 > 160 bar	307BXS	3M07BXS	307DXS	307EXS

JANUS CONTROL VALVE RELIEF VALVE

207BXS

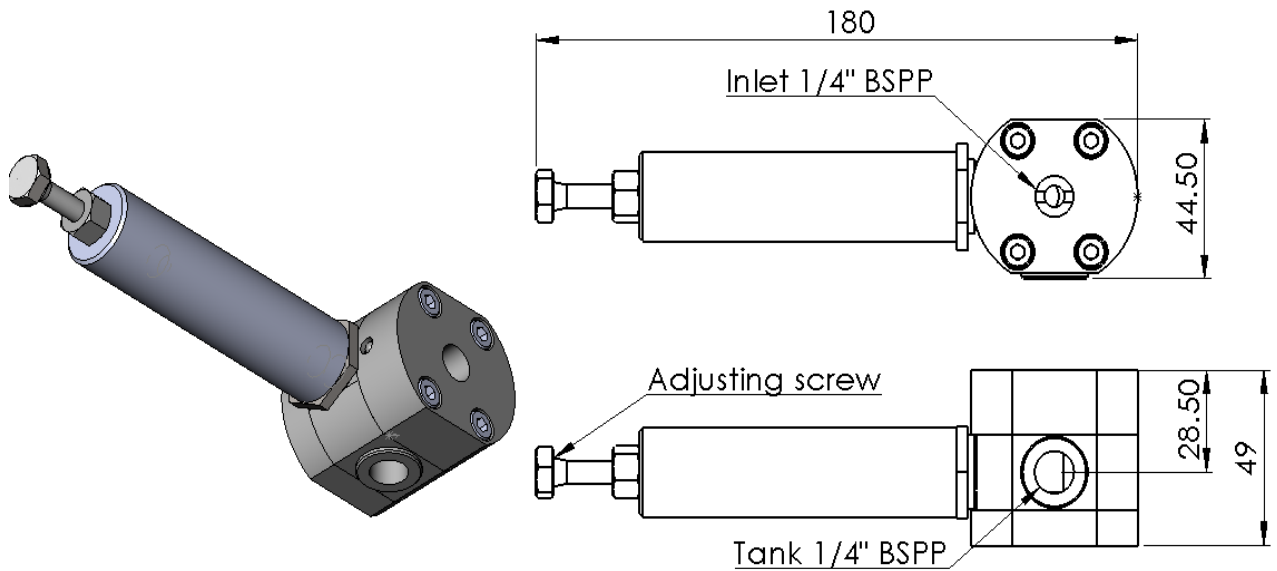

Maximum flow on the stand alone DN6 relief valve 30l/min

2M07BXS

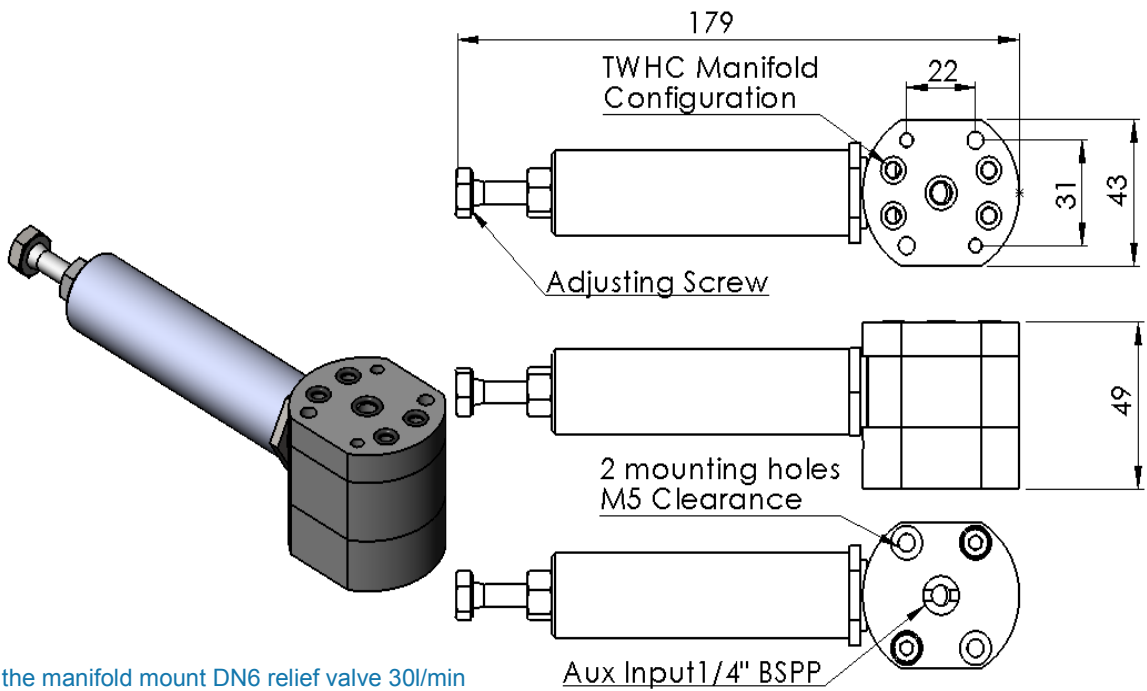

Maximum flow on the manifold mount DN6 relief valve 30l/min

JANUS CONTROL VALVE RELIEF VALVE

207DXSW

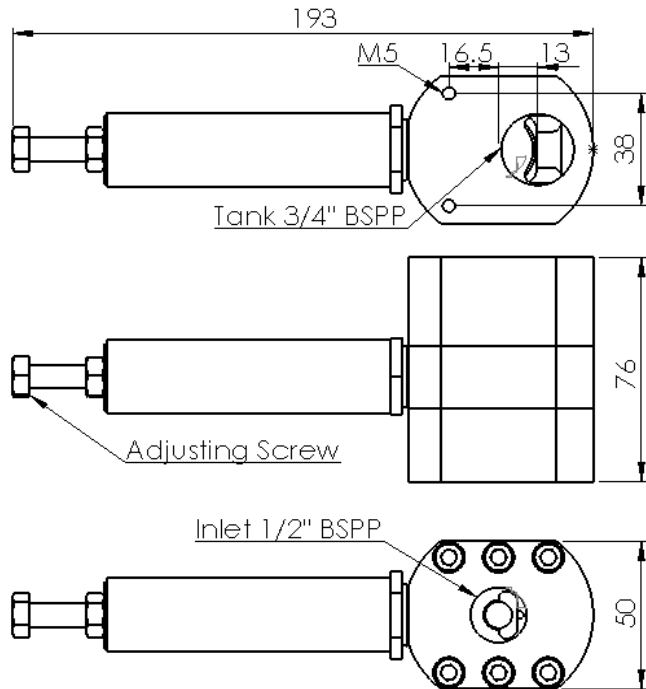
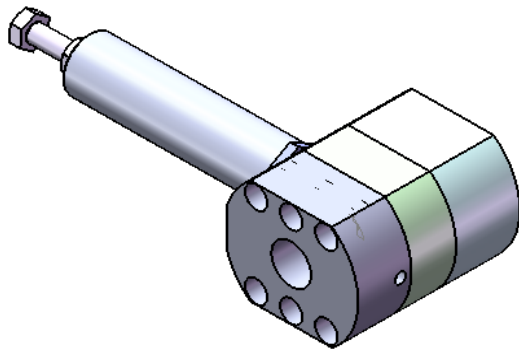

Maximum flow on the DN12 relief valve 110 l/min

207EXSW

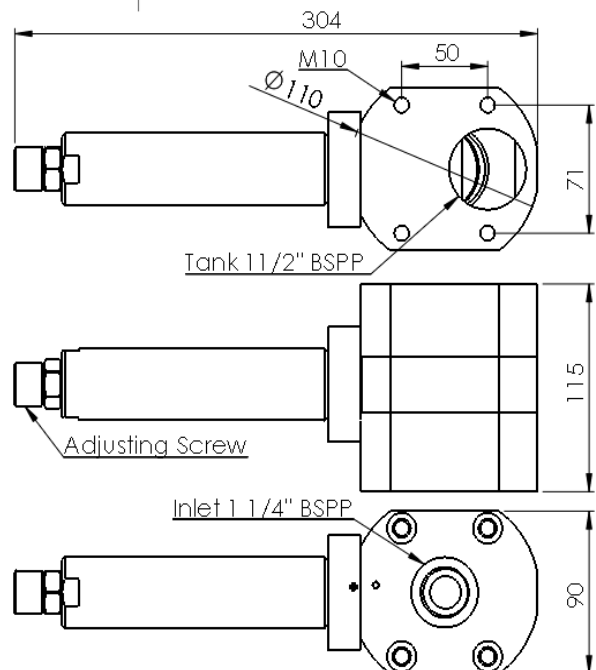
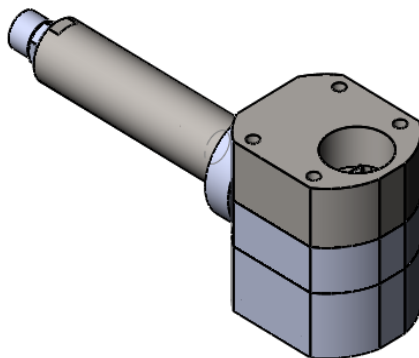

Maximum flow on the DN16 relief valve 450 l/min

The pressure control valves are not "Safety Accessories" as defined in the Pressure Equipment Directive 97/23/EC.