

OPERATION

This is a normally-open, pilot-operated, poppet-type 10-size solenoid valve with free reverse flow. When de-energized the valve allows flow from port 1 to 2 and from port 2 to 1. When energized, the pilot poppet closes allowing the valve to act as a check valve flowing from port 1 to port 2, while blocking flow from port 2 to 1. This valve comes standard with a push pin type manual override.

APPLICATIONS

This is a low leakage valve designed for use in load holding applications or as a general purpose diverter or dump valve.



Shown with Standard H16 Coil, Deutsch Connector

SPECIFICATIONS

Rated pressure*	350 bar [5075 psi]*
Rated flow at 7 bar [100 psi]	65 l/min [17 US gal/min]
Leakage	6 drops/min @ Rated pressure
Weight	0.42 kg [0.93 lb]
Cavity	SDC10-2
Standard Coil	H16 29 Watt

* Rated Pressure based on NFPA fatigue test standards (at 1 Million Cycles).

SCHEMATIC

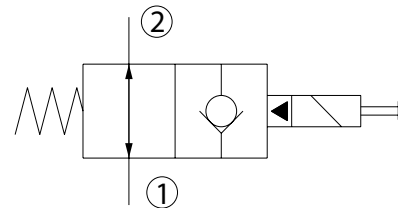

SV - Solenoid Valves
 HSVP10-NOR

PERFORMANCE CURVES

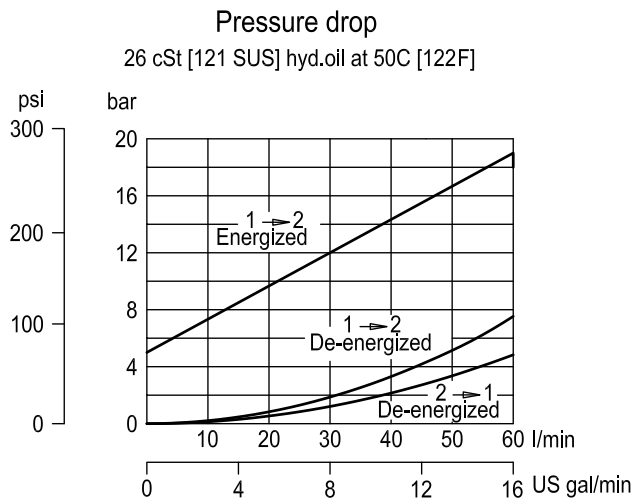

DIMENSIONS

mm [in]

Cross-sectional view

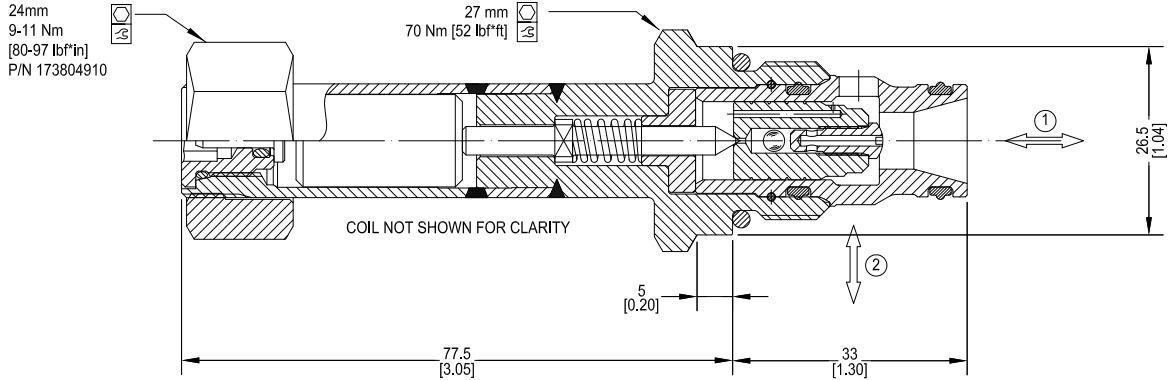

EXAMPLE CIRCUITS

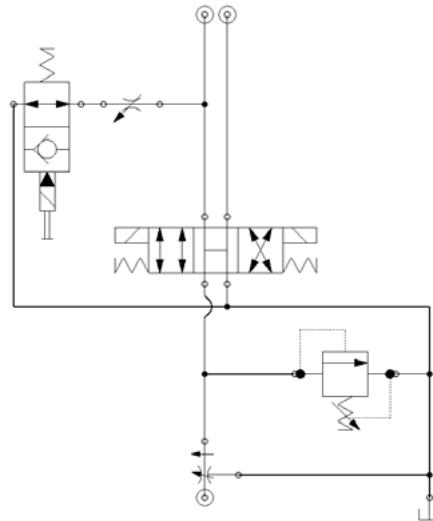

ORDERING INFORMATION

HSVP10 - NOR - H12D - DE - PN - P - 00

High Pressure Solenoid Valve,
Normally-Open, Pilot-Operated,
with Free Reverse Flow.
10 Size, Poppet Type

Coil Voltage

Code	Description
H00	No Coil
H12D	12 VDC
H24D	24 VDC

Coil Termination

Code	Description	IP Rating
00	No Coil	-
FL	Flying Lead	IP 69k
DE	Deutsch	IP 69k
AS	AMP SuperSeal 1.5 and Metri-Pack 150 type 1	IP 69k
ASDB	AMP Super Seal with Diode Bidirectional	IP 69k
DEDB	Deutsch with Diode Bidirectional	IP 69k
FLDB	Flying Lead with Diode Bidirectional	IP 69k

Bodies

Code	Port & Material	Body Nomenclature
00	Cartridge only	No Body
S3B	3/8 BSP, Ductile	SDC10-2-S3B
S4B	1/2 BSP, Ductile	SDC10-2-S4B
S6S	#6 SAE, Ductile	SDC10-2-S6S
S8S	#8 SAE, Ductile	SDC10-2-S8S

*** Aluminium bodies available for lower pressure application. Please consult factory for details.

Seal Option

Code	Seal Material	Seal kit
P	Polyurethane Single Seal	11132135
V	Viton	354000819

Manual Override

Code	Description
PN	Push Pin
OPS	Push Pin M/O Nut for Protection & Actuation
PAT	Push and Twist